

# TECHNICAL INSTALLATION MANUAL

## IRREVERSIBLE OPERATOR FOR SWING GATES AND DOORS

# KINEO 400

## 230V



**WARNING!!** Before installing, thoroughly read this manual that is an integral part of the pack

Our products if installed by qualified personnel capable to evaluate risks, comply with norms UNI EN 12453, EN 12445



The CE mark conforms to European directive  
EEC 89/336 + 92/31 + 93/68 D.L. 04/12/1992 N. 476.

# INDEX

	Pag.
PACKING CONTENTS .....	2
VIEW OF TYPICAL AUTOMATION AND NAMES OF COMPONENTS .....	3
TECHNICAL DATA.....	3
DIMENSIONS .....	4
TYPICAL CONNECTION AND CABLE SECTION.....	4
CONSIDERATIONS FOR INSTALLATION.....	5
INSTALLATION.....	5-6-7
TROUBLESHOOTING.....	8
SAFETY PRECAUTIONS .....	11

## PACKING CONTENTS

1- OPERATOR



1- KIT FASTENING PLATES AND  
RELATIVE ACCESSORIES



1- UNLOCKING KEY



1- CONDENSER (230Vca)

## VIEW OF TYPICAL AUTOMATION AND NAMES OF COMPONENTS

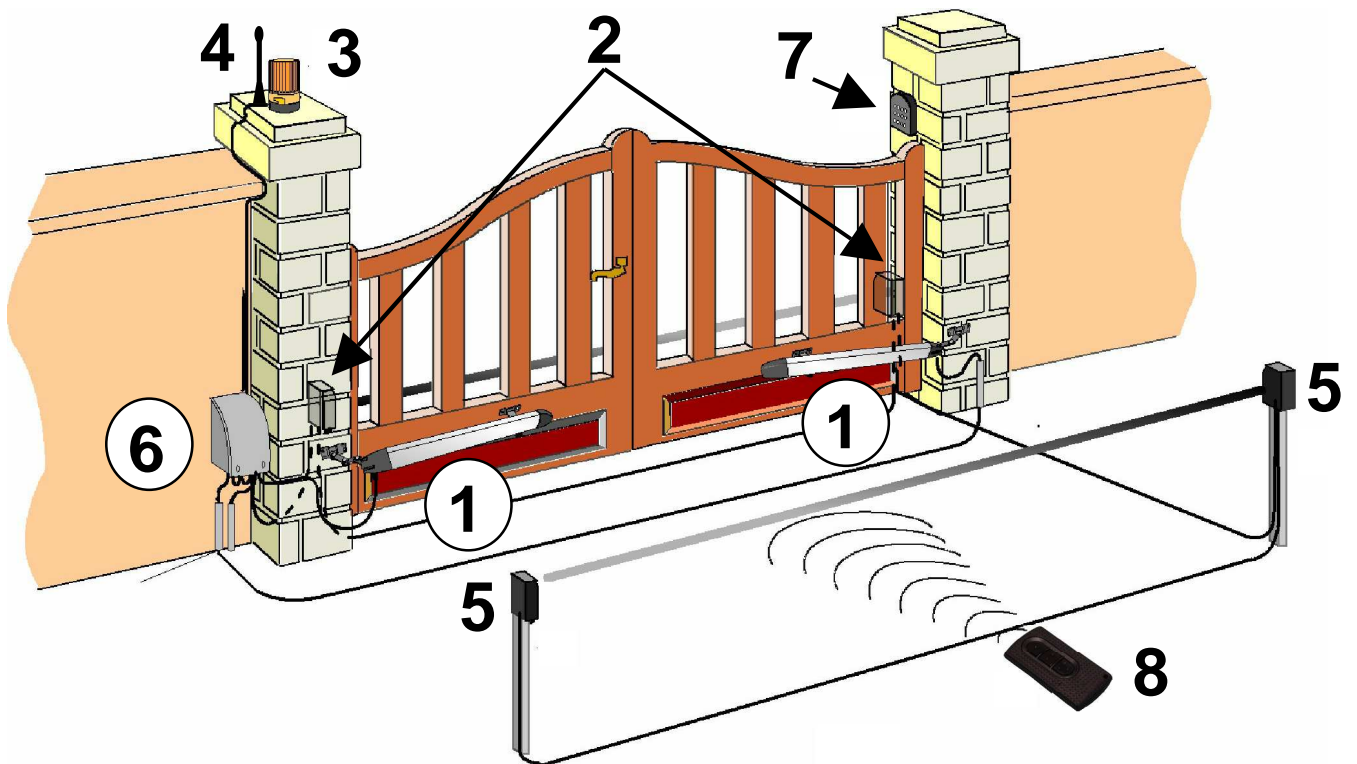

### Optimal installation

- |                           |                            |
|---------------------------|----------------------------|
| 1- Operator               | 5- Internal photocell      |
| 2- External photocell     | 6- Electronic control unit |
| 3- Flashing warning light | 7- Key-switch              |
| 4- Antenna                | 8- Remote control          |

### TECHNICAL DATA

Max. weight of gate	250 Kg
Max. width of gate	3 mt
Motors power supply	230 Vac
Motor power	200 W
Motor RPM	1400
Condenser	10 $\mu$ F
Mechanical unlock for emergency manoeuvre	With key
Working temperature	-20°C / +55°C
Weight	6.5 Kg
Protection rating	IP 55
Opening time 90°	15 sec
Rod stroke	400 mm
Force of thrust	2900 N
Motor current input	1 A

# DIMENSIONS

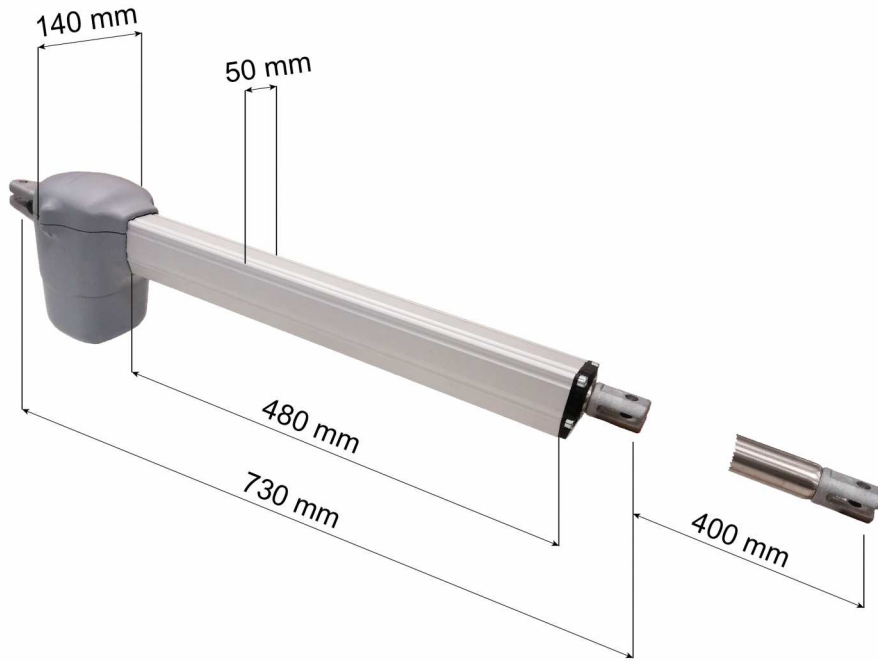

# TYPICAL CONNECTION AND CABLE SECTION

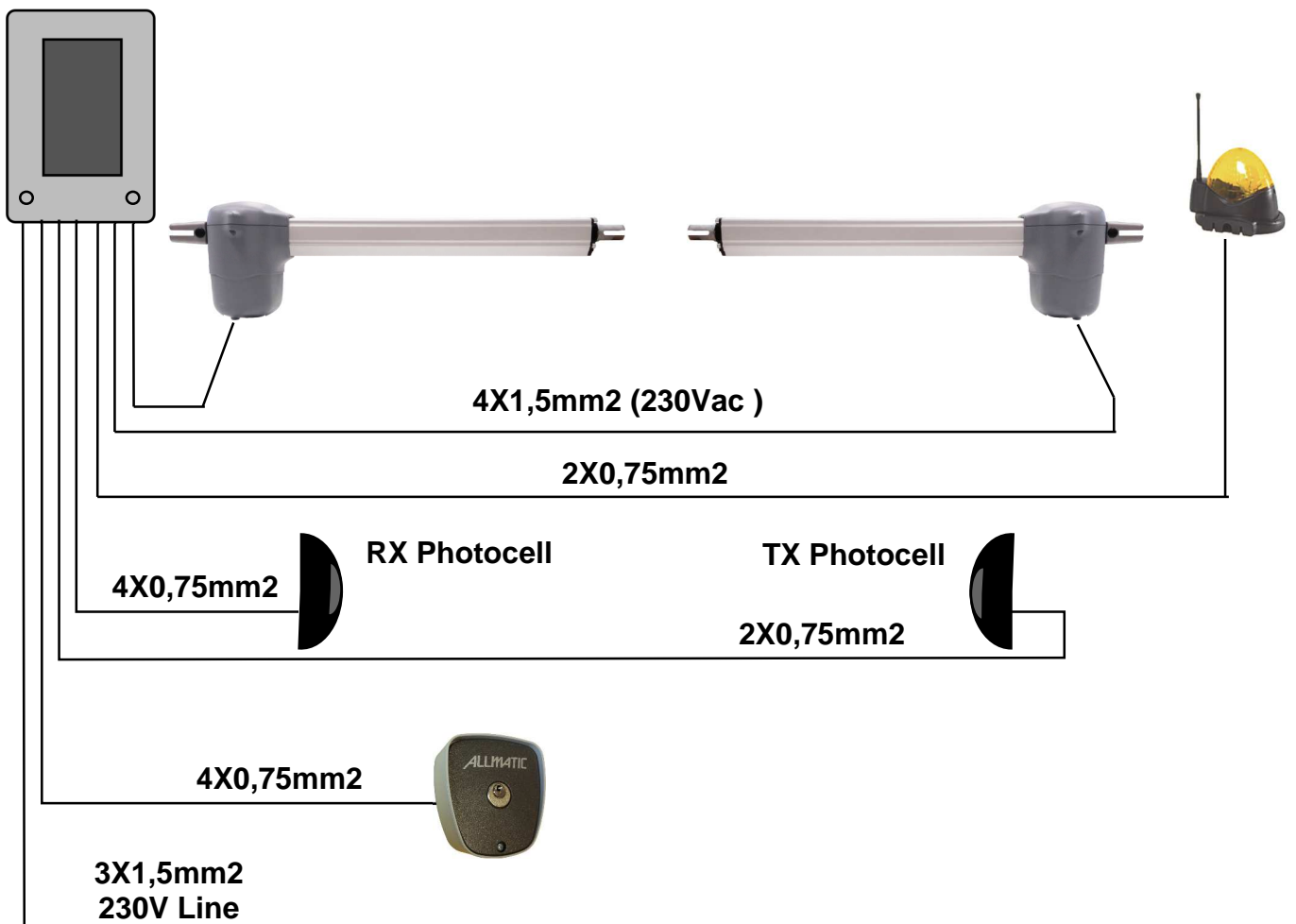

# CONSIDERATIONS FOR INSTALLATION

- The installation and testing operations must be performed solely by qualified personnel in order to guarantee the proper and safe operation of the automatic gate.
- The company declines any responsibility for damage caused by incorrect installations due to incompetence and/or negligence.
- Before assembling the automatism, check that the gate is in perfect working order, hangs well on its hinges and is suitably lubricated. It must also comply with the safety standards in force in the country of installation..

## INSTALLATION

- 1- Before fastening the brackets provided, establish the coordinates using the data given in **Table 1**, bearing in mind that they are valid if the operator is at maximum extension minus one centimetre of the available stroke (**CD**) when the gate is closed to obtain maximum working efficiency.
- 2- Data **B** in the table, with reference to the single values **A**, are to be considered as values (recommended).
- 3- To anchor the piston, use the fastening brackets provided.

### COORDINATES AND TABLE

- 1- Establish coordinates **A + B** that are to be used.
- 2- **Note:** The stroke used (**CU**) of the operator must never be equal or greater than the available stroke (**CD**)
- 3- The sum of coordinates **A + B**, establishes the stroke used **CU**.

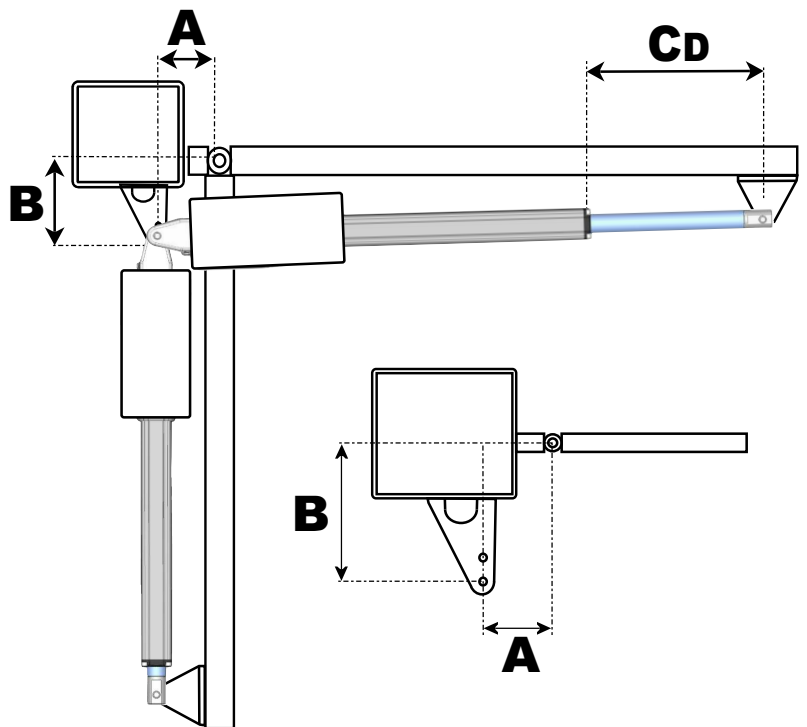

**TABLE 1**

<i>Opening angle</i>	A	B	Cu
90° Available stroke = 400mm (without limitswitch)	160	160	320
	175	175	350
	185	185	370
	200	200	400

**Note1:**  $A+B = CU$  (Stroke used)      $CD =$  (Available stroke MAX) = 400mm

## INSTALLATION OF FASTENING PLATES

Fix the back plate to the pillar.(**FIG. 1**)

Anchor the rear part of the piston to the plate and fasten it firmly.( **FIG. 2**)

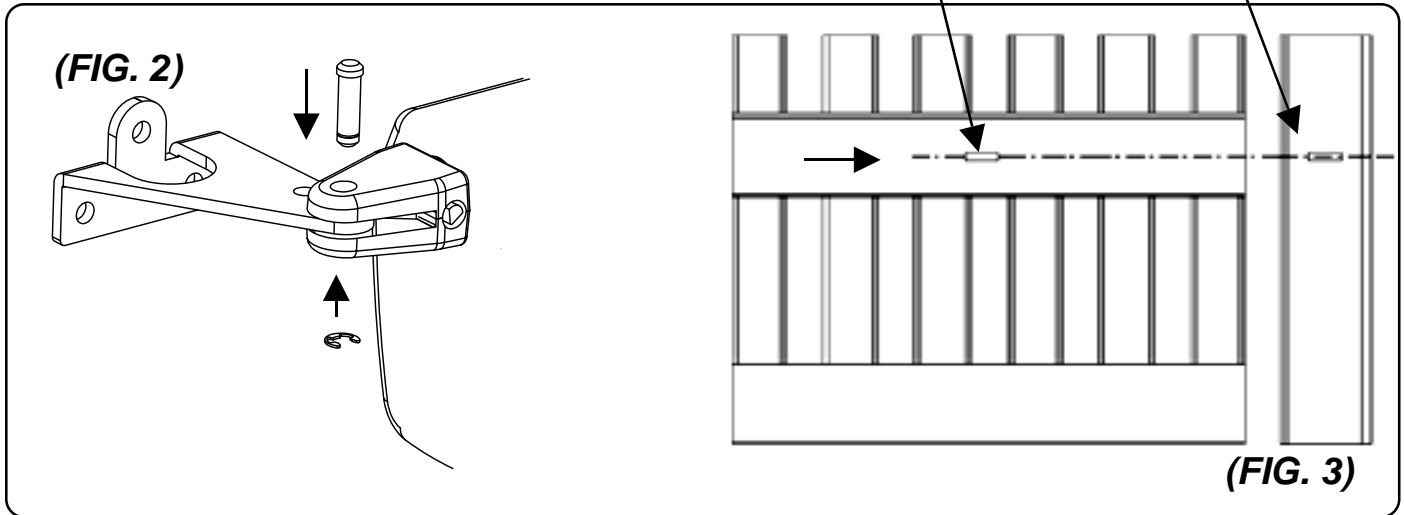
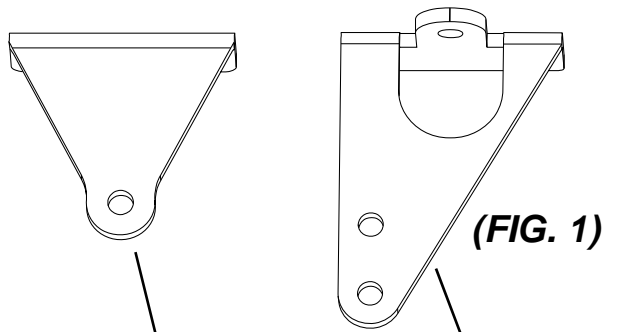

**Warning!** When establishing the height off the ground at which to fasten the plate to the post (**fig. 1**), keep in mind that the plate for anchoring the piston to the gate must be fastened at the same level (**fig. 3**)

### ***Installing the anchor plate on the piston to the gate***

1. Fit the anchor plate onto the piston (**fig. 4**)
2. Close the gate
3. Move the piston with the plate already fitted towards the gate
4. Move the fitting to limit stop, then move it back by approximately 1cm and mark the position of the plate.
5. realize the same operation in opening.
6. If positions correspond, fix the plate on the gate; otherwise revise **A** and **B** units (**table 1**)

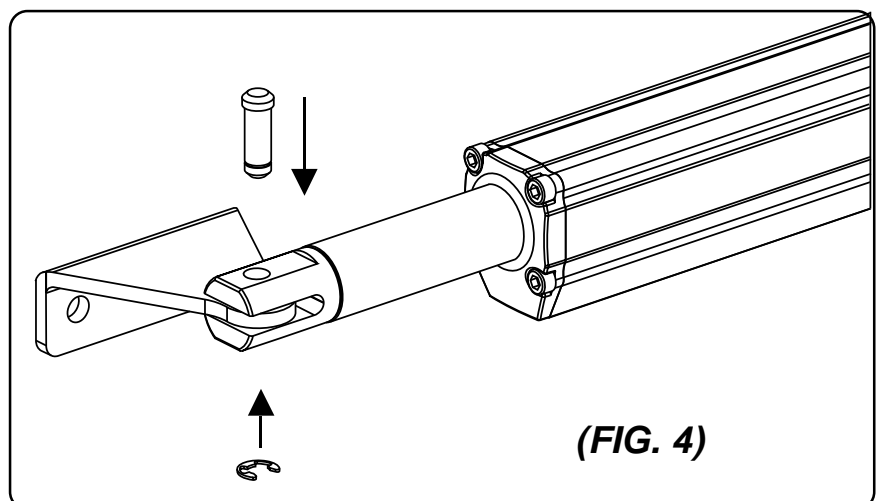

## ***Limitswitch adjustment ( OPTIONAL)***

- The actuator may be provided with mechanical limitswitches in opening and/or closing (**optional**).
- To adjust, slacken the screws on the limitswitch and move it to the desired position.
- Lock the screws..



## ***Release procedure***

To unlock the actuator insert the supplied key into the pin.  
Turn the key 90° and unlock.

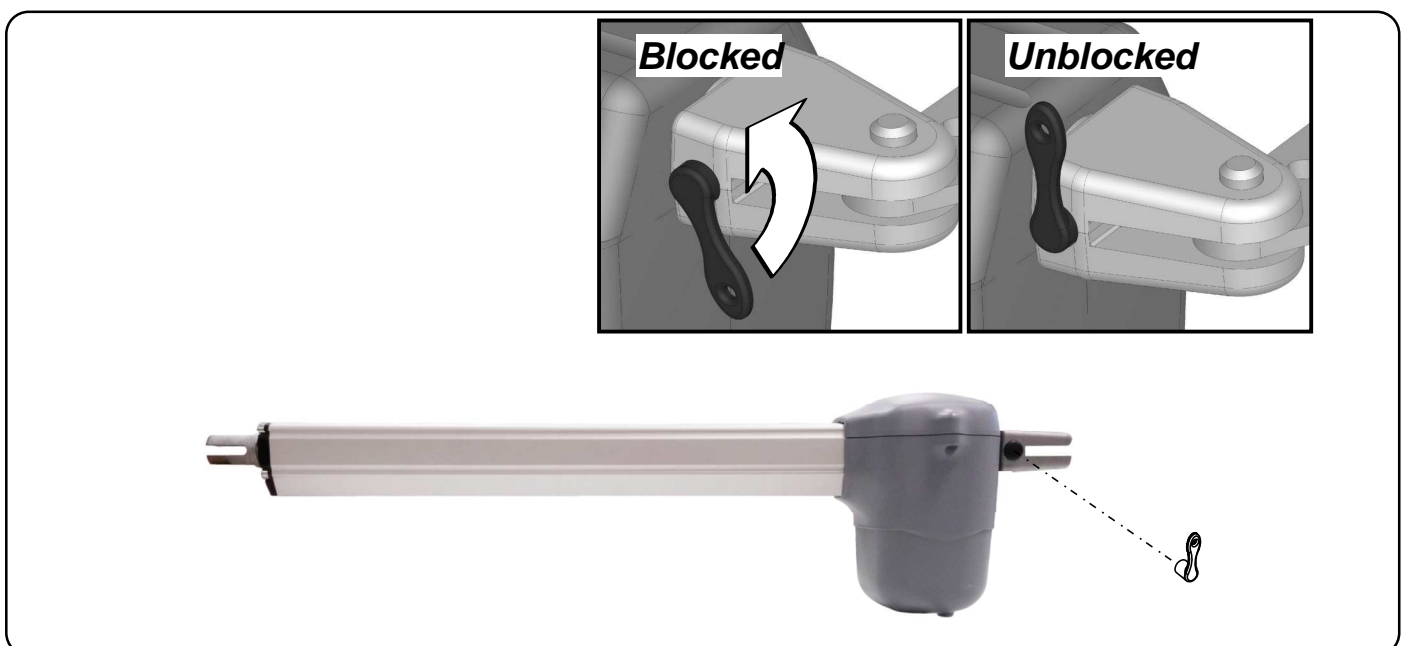

## TROUBLESHOOTING

PROBLEM	PROBABLE CAUSE	SOLUTION
On giving a command with the remote control or with the key-switch, the gate doesn't open or the motor doesn't start	230 volt mains voltage absent	Check master switch
	Emergency STOP present	Check for any STOP selectors or commands. If not used, check jumper on STOP contact input on the control board
	Fuse blown	Replace with one of same value.
	Power cable of motor or motors not connected or faulty.	Connect the cable to appropriate terminal or replace.
	The photocell is not functioning or the beam is interrupted	Check the connection, remove any obstacle across the beam
On giving a command with the remote control, the gate doesn't open but works with the key command	The remote control has not been memorised or the battery is flat	Carry out the remote control learning procedure on the radio receiver or replace the battery with a new one..
The gate starts, but stops immediately	The force of the motor or motors is insufficient	Check the settings of the control unit
One wing opens and the other closes	The connection is not correct	Invert the connection of the cable of the motor which rotates in the wrong sense

**N.B. - If the problem persists, contact your Retailer or the nearest Service Centre**





NOTES

---

---

---

---

---

---

---

---

---

---

---

---

---

---

---

---

---

---

---

---

---

---

---

## **SAFETY PRECAUTIONS**

These warnings are an essential, integral part of the product and must be given to the user. They provide important indications on the installation, use and maintenance and must be read carefully. This form must be preserved and passed on to subsequent users of the system. The incorrect installation or improper use of the product may be dangerous.

### **INSTALLATION INSTRUCTIONS**

- The installation must be performed by professionally skilled personnel and in compliance with current local, state, national and European legislation.
- Before beginning the installation, check the integrity of the product.
- The laying of cables, electrical connections and adjustments must be workmanlike performed.
- The packing materials (cardboard, plastic, polystyrene, etc.) are a potential hazard and should be disposed of correctly and not left within reach of children.
- Do not install the product in potentially explosive environments or environments disturbed by electromagnetic fields. The presence of inflammable gases or fumes is a grave danger to safety.
- Set up a safety device for overvoltage, a disconnecting and/or differential switch suitable for the product and conforming to current standards.
- The manufacturer declines any and all responsibility for product integrity, safety and operation in the event incompatible devices and/or components are installed.
- Solely original spare parts should be used for repairs and replacements.
- The installer must provide all the information relating to the operation, maintenance and use of the individual parts, components and system as a whole.

### **WARNINGS FOR THE USER**

- Read the instructions and enclosed documentation carefully.
- The product must be used for the express purpose for which it was designed. Any other use is considered improper and therefore hazardous. In addition, the information given in this document and in the enclosed documentation may be subject to modifications without prior notice. It is given as an indication only for product application. The company declines any responsibility for the above.
- Keep products, devices, documentation and anything else provided out of reach of children. In the event of maintenance, cleaning, breakdown or faulty operation of the product, cut off the power and do not attempt to operate on the product. Contact solely the professionally skilled personnel responsible for these operations. Failure to adhere to the above indications may be dangerous.

**The data and images are for guidance only  
reserves the right to change at any time characteristics of the products described in its  
sole discretion, without notice.**